

ASSEMBLY INSTRUCTIONS

**STEPS:** 1. Assemble Part #24124 Inside Stop to housing with Part #44228 Inside Stop Retaining Stud. (Will be a force fit) 2. Assemble Part # 44133 Inside Insert. (Half moon section of insert should rotate freely between stopping points of stop.) 3. Assemble Part # 34037 Washer over housing side of insert. 4. Assemble Lever Handle or Panic Hardware Rocker Arm over insert while lining up Roll Pin hole. 5. Insert Part # 54166 Roll Pin. (Will be a force fit.) Test Lever Handle/Panic Hardware rocker Arm for rotational free movement.

Ⓐ = Part # 74200 - Panic Hardware  
Part # 44105 - Inside Lever Handle

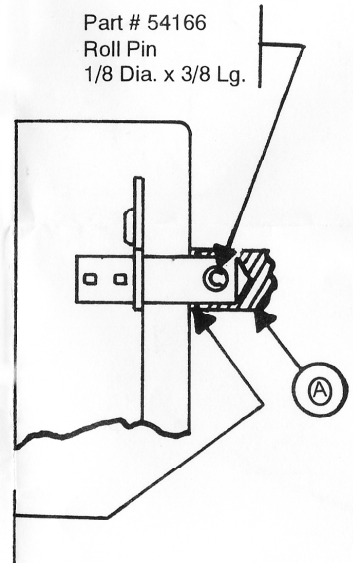
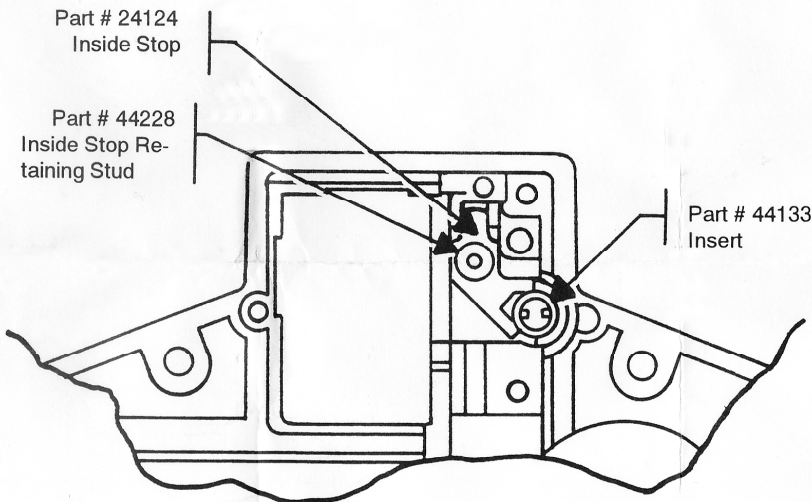

**SIMPLEX® ACCESS CONTROLS**

Division of ILCO UNICAN Corp.  
2941 Indiana Avenue, P.O. Box 4114, Winston Salem, NC 27115-4114  
TEL.: (919) 725-1331 • FAX: (919) 725-3269 • FAX: (800) 346-9640

ASSEMBLY INSTRUCTIONS FOR LEVER HANDLE/PANIC  
HARDWARE KITS

Order Online  
[www.MrLock.com](http://www.MrLock.com)