

**B1921 / B1923 PIVOT ASSEMBLY**

(RIGHT HAND SHOWN).

PRODUCT MUST BE INSTALLED  
ACCORDING TO ALL APPLICABLE  
BUILDING AND LIFE SAFETY CODES

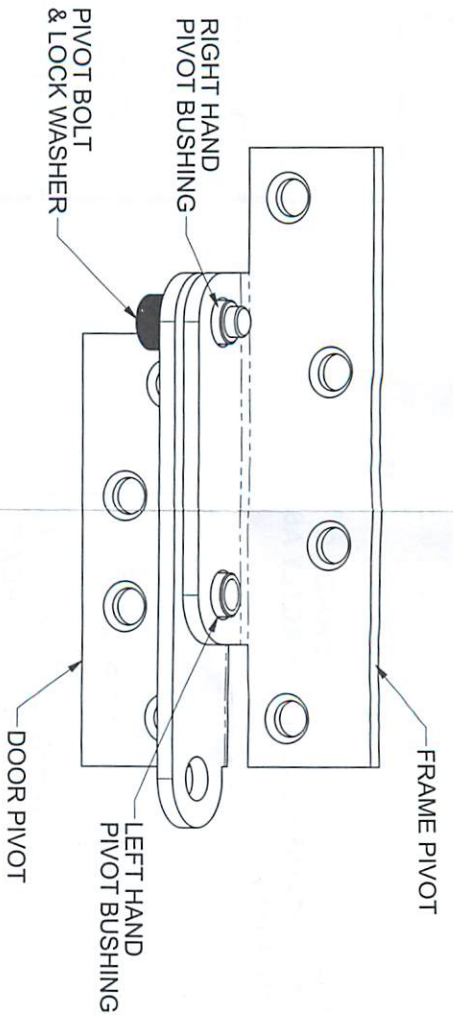

**STEP 1**

TO CHANGE THE HANDING:  
- REMOVE THE PIVOT BOLT AND  
LOCK WASHER USING ALLEN KEY #5/16 FOR B1921  
AND #3/8 FOR 1923 (Fig. 1)

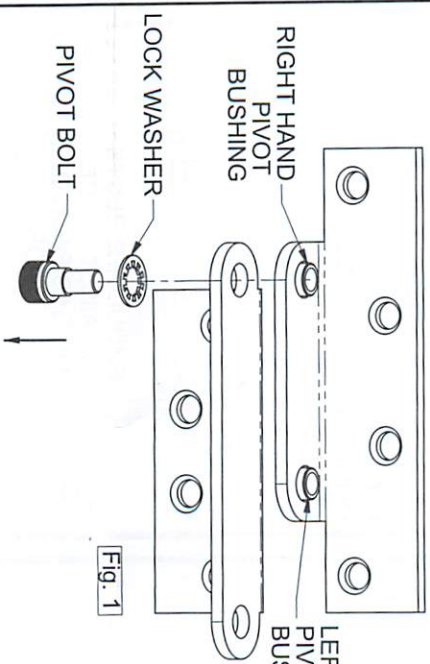

**STEP 2**

- SECURELY FASTEN LOCK WASHER AND PIVOT BOLT  
TO DOOR PIVOT AT THE DESIRED HANDING.  
- REPOSITION THE DOOR PIVOT USING THE  
ALTERNATE BUSHING ON THE FRAME PIVOT.  
(Fig. 2 SHOWS THE B1921 / B1923 PIVOT  
ASSEMBLY AS BEING LEFT HANDED).

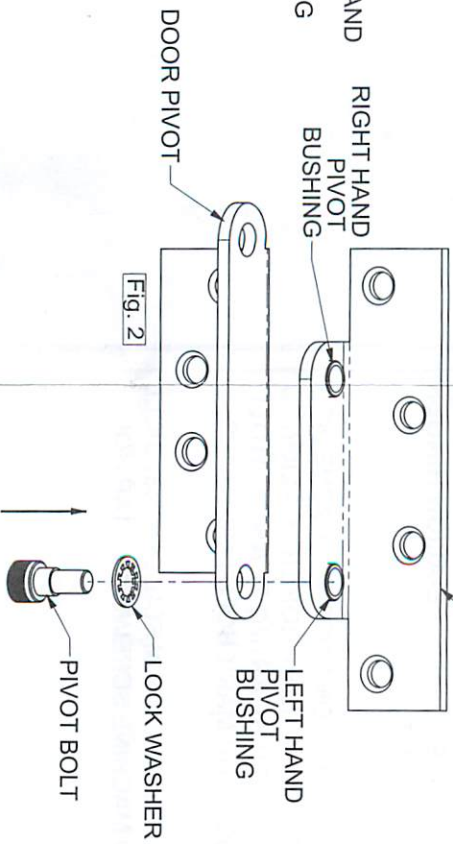

**STEP 3**

- REMOVE THE PIVOT BUSHING THAT IS NOT  
BEING USED TO PREVENT INTERFERENCE.  
(Fig. 3 SHOWS THE B1921 / B1923 PIVOT  
ASSEMBLY AS BEING LEFT HANDED).

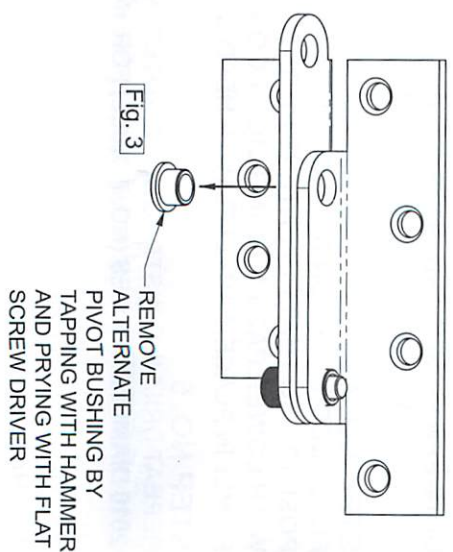

**ASSA ABLOY**

Markar Architectural Products  
4226 Transport St.  
Ventura, CA 93003  
Phone: 800-824-3018  
Fax: 800-243-3656  
www.markar.com

FULL SURFACE REINFORCING PIVOT HINGE  
(B1921/B1923)

M80-0180-1923

Rev. E

ECN: M1227

Date: 07/15/11

Page 2 of 2

Appvd: MP Date: 07/21/11

**INSTALLATION INSTRUCTIONS**

STOP



**AVOID ERRORS  
READ CAREFULLY**

STOP



**STEP NO. 1**

TO LOCATE PIVOT ON FRAME, HOLD COMBINATION SQUARE IN CORNER OF FRAME AND PLACE INSTALLATION TEMPLATE AGAINST SQUARE EXACTLY AS SHOWN. SPOT HOLE CENTERS WITH CENTER PUNCH.

**STEP NO. 2**

DRILL HOLES REQUIRED AS PER SCHEDULE.

**METAL FRAME**

DRILL .2010 DIAMETER HOLES (NO. 7 DRILL) FOR 1/4-20 MACHINE SCREW AND TAP HOLE.

*NOTE: IF MATERIAL THICKNESS IS NOT SUFFICIENT OR WHEN HOLLOW METAL FRAMES ARE NOT REINFORCED, USE #14 x 1 1/4" TYPE A SHEET METAL SCREWS.*

**WOOD FRAME**

DRILL PILOT HOLES AND INSTALL WOOD SCREWS.

**STEP NO. 3**

WITH DOOR IN PLACE, CHECK TO BE SURE THAT HINGES ARE FIRMLY ATTACHED AND THERE IS PROPER CLEARANCE BETWEEN DOOR AND FRAME AT ALL SIDES, INCLUDING BOTTOM OF THE DOOR.

IF DOOR TENDS TO SAG AWAY FROM HINGE JAMB AT TOP, DRIVE WEDGES BETWEEN FRAME AND DOOR AT OPPOSITE STRIKE SIDE AND RE-ALIGN HINGES UNTIL DOOR IS PROPERLY POSITIONED TO SWING FREE.

**STEP NO. 4**

PLACE DOOR PORTION OF PIVOT (WITH PIVOT IN PLACE) ON DOOR AND MOVE INTO POSITION SO THAT PIN ENTERS BRONZE BUSHING. WHEN PROPERLY ALIGNED WITH LOWER PART MAKING LIGHT CONTACT WITH BEARING FLANGE, HOLD FIRMLY IN PLACE, PARALLEL WITH HEAD OF DOOR AND MARK HOLE LOCATIONS.

**STEP NO. 5**

REPEAT DRILLING INSTRUCTIONS NOTED IN STEP NO. 2 FOR METAL DOORS, DRILL .2010 DIAMETER HOLES (NO. 7 DRILL) FOR 1/4-20 MACHINE SCREWS AND TAP HOLE.

*NOTE: USE TWO SLEEVE BOLTS FURNISHED WITH EACH PIVOT. USE AS REQUIRED FOR HOLLOW METAL, OR MINERAL CORE DOORS. (SEE FIG. 3) DRILL 1/4" HOLE THRU DOOR. ENLARGE HOLE ON SIDE OPPOSITE PIVOT TO 3/8" DIAMETER FOR SLEEVE BOLT.*

PRODUCT MUST BE INSTALLED  
ACCORDING TO ALL APPLICABLE  
BUILDING AND LIFE SAFETY CODES

**FIGURE 1**  
(LEFT HAND SHOWN)

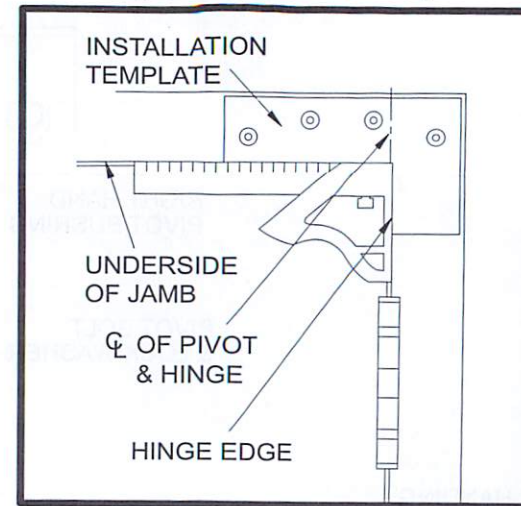

**FIGURE 2**  
(LEFT HAND SHOWN)

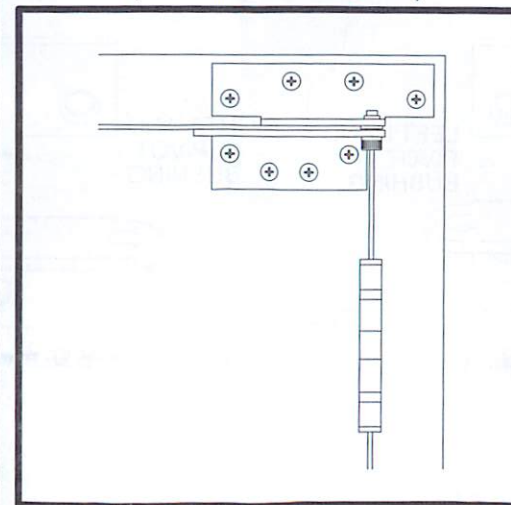

**FIGURE 3**

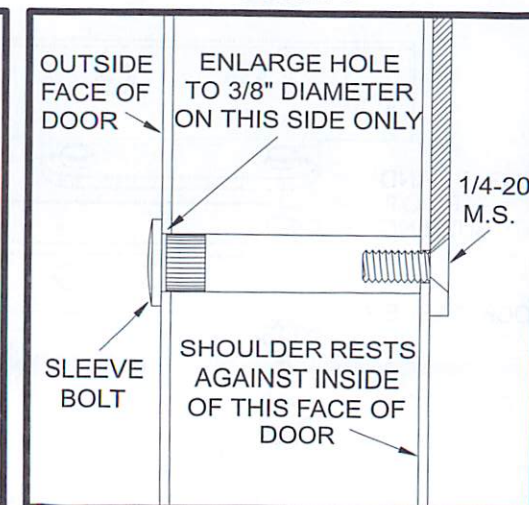

Markar Architectural Products  
4226 Transport St.  
Ventura, CA 93003  
Phone: 800-824-3018  
Fax: 800-243-3656  
www.markar.com

FULL SURFACE REINFORCING PIVOT HINGE  
(B1921/B1923)

M80-0180-1923 Rev. E ECN: M1227 Date: 07/15/11

INSTALLATION INSTRUCTIONS

Page 1 of 2 Appvd: MP Date: 07/21/11