



**Application**

The 6200 Series primary lock provides fully mechanical pushbutton access control with no electrical wiring, electronics, or batteries. Exterior access is by combination. Egress is by interior knob and is free at all times. The lockset automatically relocks each time the door closes.

6200 Series locksets provide affordable pushbutton convenience for commercial or residential applications. These locks are ideal for front and rear doors, garages, garden cabanas, utility rooms and workshops.

The pushbutton design eliminates problems associated with the issue, control, and collection of keys and magnetic cards. The combination can be quickly and easily changed to ensure continued maximum security once employees, tenants, or guests leave, saving the cost of new keys, key cylinders, magnetic cards, and card-encoding devices. The combination is changed without removing the lock from the door.

**Features**

**Operation:** Depress the buttons in the correct sequence and turn the thumbturn to retract the deadlocking latch.

**Thousands of possible combinations:** Authorized individuals can change the combination in seconds. One or all five buttons can be used in the combination - individually or with two or more buttons depressed simultaneously.

**Easy to install on wood or metal doors:**

The lock retrofits 2 1/8" (54mm) standard bore cylindrical locksets with a 2 3/8" (60mm) or 2 3/4" (70mm) backset.

**Rugged & weather resistant:**

The lock is wear-tested for intensive use. Suitable for indoor or outdoor locations.

**Includes:** Standard strike and strike box, installation instructions, full-scale template, spanner wrench with combination change tool.

**Specifications**

**Construction:** Cylindrical lock housing; all metal; cast front housing; force-proof clutch-protected thumbturn; interior reinforcing plate; interior brass trim plate; fixed wrought brass knobs

**Door thickness:** 1 3/8" (35 mm) to 2 1/4" (57 mm), wood or metal

**Strike:** TS strike plate; DB strike box

**Latch & backset:** 1/2" (13 mm) throw latch, floating front, 2 3/4" (70mm) backset (carries UL/ULC 3-hour fire rating for "A" labeled doors)

**Optional Latch & backset:** 1/2" (13 mm) throw latch, flat front, 2 3/4" (70mm) or 2 3/8" (60mm) backset (carries UL/ULC 3-hour fire rating for "A" labeled doors)

**Installation:** ASA 161 door preparation with additional feature holes: 2 1/8" (54 mm) diameter through bore for housing; 1" (25 mm) diameter cross bore for latch; 2 x 1/4" holes for mounting bolts, 5" (127 mm) minimum stile required. The lock can be inverted if the existing auxiliary lock obstructs installation.

**Door handing:** Factory-handed left; field reversible

**Control:** Combination change tool

**Finishes:** 60 Gold Tone, 67 Almond, 85 Black or 86 Gray powder paint.

**Weight:** 4.5 lbs. (2 kg)

**Dimensions**

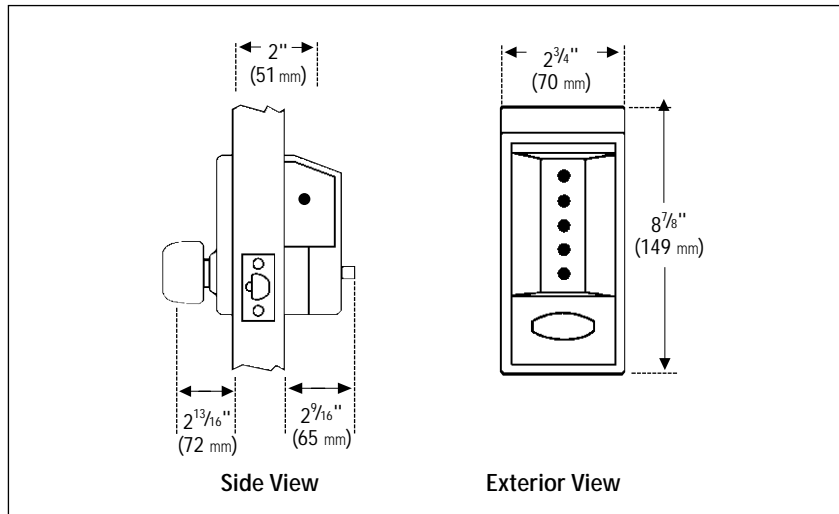

**Ordering Information**

**Example**

Model 6204 with floating front latch, 2¾" backset gold tone finish, packaged 1 per box.



Build the part number with the features you require:

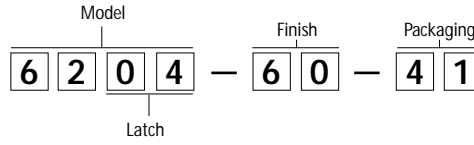

Model	Description	Latch	Backset
6204	6200 Series cylindrical primary lockset	½" (13mm) throw, floating front	2¾" (70mm)
6214	6200 Series cylindrical primary lockset	½" (13mm) throw, flat front	2¾" (70mm)
6218	6200 Series cylindrical primary lockset	½" (13mm) throw, flat front	2⅝" (60mm)

Finish	Description
60	Gold Tone
67	Almond
85	Black
86	Gray

Packaging	Description
41	1 per box